



# PARTICIPANT HANDBOOK



Automotive

Language:  
English

## CNC OPERATOR



N · S · D · C  
National  
Skill Development  
Corporation

**Orion Edutech**<sup>®</sup>  
ISO 9001:2015 CERTIFIED  
Funded Partner of NSDC

**CNC OPERATOR**  
**(MACHINING TECHNICIAN)**

# **TABLE OF CONTENTS**

## **CNC OPERATOR - (MACHINING TECHNICIAN)**

### **Chapter - 1**

---

#### **Introduction to CNC Operator**

- 1.1 The Maiden Spark of Civilization
- 1.2 Introduction to Mechanical Industry
- 1.3 What is CNC?
- 1.4 Job Responsibilities of CNC Operators
- 1.5 Advantages of CNC

### **Chapter - 2**

---

#### **Different Types of Machining Processes**

- 2.1 Machining Processes: Various Types
- 2.2 Impact of the Machining Processes
- 2.3 Fundamental of Machine and Mechanics
- 2.4 Safety Guidelines
- 2.5 Lubricants and Coolants

### **Chapter - 3**

---

#### **Tolerance and Fit and the Gear Changing Mechanism**

- 3.1 Tolerance and Fit
- 3.2 Tolerance Systems
- 3.3 Types of Fit

### **Chapter - 4**

---

#### **Maintain Safe and Healthy Environment Emergency Situations**

- 4.1 Fire
- 4.2 Evacuation Plan during Fire
- 4.3 Classifications of Fire
- 4.4 First Aid Fire Fighting Appliances
- 4.5 Earthquake
- 4.6 Evacuation Procedure
- 4.7 Assembly Area

### **Chapter - 5**

---

#### **Proper Hygiene to Avoid Diseases**

- 5.1 Overview
- 5.2 What is Hygiene?
- 5.3 Importance of Hygiene
- 5.4 Few things you can avoid by proper hygiene
- 5.5 Hygiene at Workplace
- 5.6 Few Diseases Pertaining to Unhygienic Atmosphere
- 5.7 Steps to Maintain Proper Hygiene

## Chapter - 6

---

### **5s at the Work Premises**

6.1 Basic Concept of 5S

6.2 Components of 5S

6.3 Definition of Waste Material

6.4 Management of Waste Materials

6.5 Risks Associated to Waste Materials

6.6 Precautionary Steps While Handling Waste Materials

6.7 TQM Process

## Chapter - 7

---

### **Manage to Meet Requirements**

7.1 Overview

7.2 Planning Phase (Make a Blueprint)

7.3 Shifting Priority on the Basis of Urgency

7.4 Importance of Discipline

7.5 Time Management



Module – 1 and Module – 2

**CHAPTER 1**  
**INTRODUCTION TO CNC OPERATOR**

**LEARNING OUTCOMES:** 

- Knowing brief history of machining industry
- Learning the definition of CNC
- Understanding the advantages of CNC
- Knowing the cons of introduction of CNC
- Understanding the job responsibilities of CNC operators

---

**PRE-SESSION ACTIVITY:**

The trainer will ask the trainees to form groups of 4. After allotting the groups, the trainer will ask the trainees to discuss among themselves (in group) about the basic introduction of each other. Each member of a group should be aware of others' name, date of birth, hometown and favourite game. The trainer will give them 15 mins to discuss. After 15 mins, the trainees (members of the group) should give introduction of another person.

**1.1 The Maiden Spark of Civilization**



The first man, rather the pre historic ape-man who knowingly or unknowingly struck two pieces of stones and built fire, is unknown to us. An inference might be drawn here that the person himself was not aware of the fact that he/ she is the pioneer of the civilization that to follow. Now, think of a day without the aid of modern gadgets like phone, laptop, computer, Xerox machine etc. We could even act like a fish out of water under such a circumstance where we would not have the privilege of using these gadgets. In other words, these things have become indispensable parts of our daily life.

This fact leads to a conclusion that from the very first days of our so called “humanhood”, we have become dependent on technology. On the flip side of the coin, the constant development in the field of technology has enabled human beings to attain the status of supremacy over other specieses of animals. The unending strive for betterment is the fuel to our journey as mankind.

## CNC Operator (Machining Technician)

---

Introduction of modern technology in the industrial field was inevitable and by far the implementation of the same has proven to be of great value in terms of various parameters like cost effectivity, productivity, accuracy etc. Think of the days two generations ago. People used to operate gigantic machines manually. This even led to innumerable accidents and mishaps. However, now, since the implementation of modern technology, we are able to controll things by the help of various computer operated programs. Even things can be controlled from a distance of 384,400 kms. We are launching artificial satellites which revolve around the moon and send us various information. This could have been impossible if the technology didn't allow us to do the same.

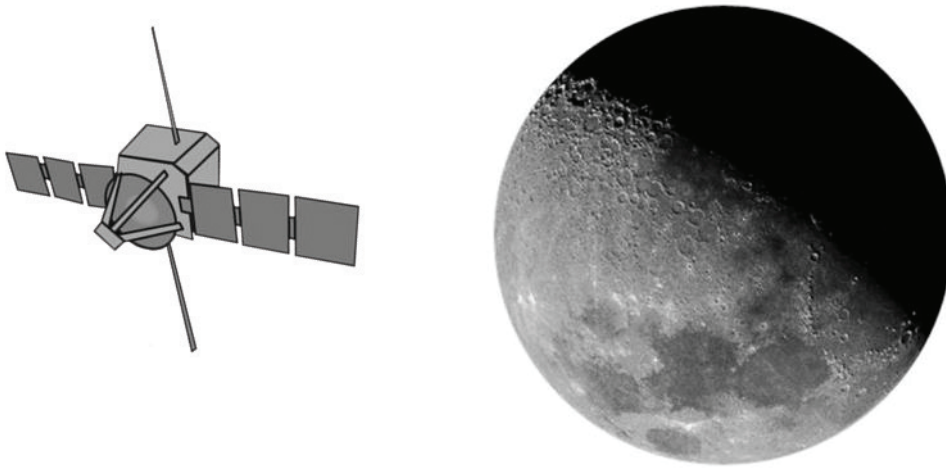

### 1.2 Introduction to Mechanical Industry

The economists and the economical historians agree with a common notion that since domestication of animals and introduction of harvesting, Industrial Revolution is the biggest event that has changed the direction of the propagation of human civilization. A brief history of Industrial Revolution is given below for the better understanding of the introduction of machines and chemicals and wide usage of thermal and steam power as sources of energy.



### **1.2.1 Industrial Revolution**

Industrial Revolution indicates to a time period from 1760 to 1840 roughly, when the introduction of modern equipment propelled the growth of industry to its zenith. The hand controlled machines (human operated) were replaced by new gadgets which were more productive and at the same time cost effective. Other than the introduction of these machines, various chemicals especially in textile field were used extensively to put up a steady and fast production. Implementation of thermal and steam power aided to the industrial growth as well. As an outcome of all these events, the overall structure of industry was metamorphosed to something colossal which was never thought of before.

The revolution took place rather it was initiated from Great Britain as the inventors were mainly British. However, the scope and implementation of the revolution were spread over the period of time, first in the European continent and then to the rest of the world, especially, the colonies of the European countries. The other factor that influenced the industrial revolution is the Renaissance that went hand in hand with the event.

The main points of the Industrial Revolution is –

- Introduction of new machines
- Implementation of chemical industry especially in the textile industry
- Growth of iron industry
- Incorporation of new energy sources like thermal and steam energy
- Initiation of new economic infrastructure
- Invention of new machines and mechanical tools
- Materialization of new GDP (Gross Domestic Development) process
- Revolution in the mining industry

Here is a list of new inventions that opened new windows of opportunity and growth –

- Verbruggen's Horizontal Boring Machine



- Maudslay's Early Screw-cutting Lathes

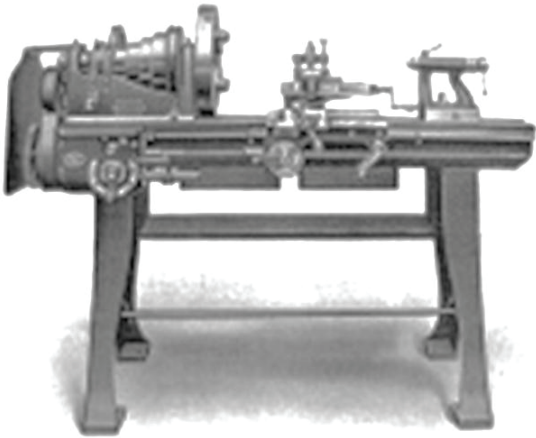

- Cement



- Gas Light



- Glass Making

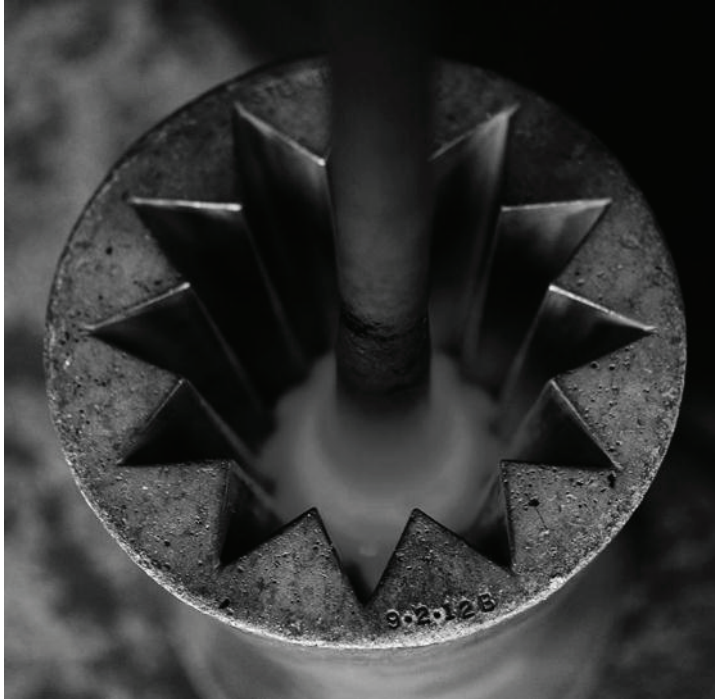

- Steam Power

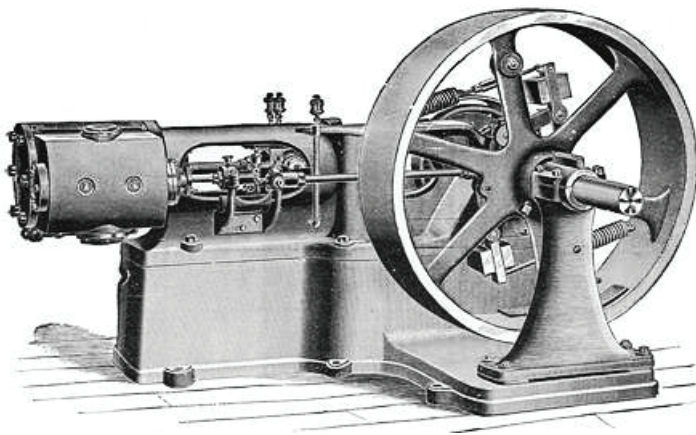

Apart from the above pictures, there are other inventions that aided the industrial revolution as well. Now, let's briefly discuss the transition between the manually controlled machines and the advanced machines that were outcomes of the industrial revolution.



### 1.2.2 Transition

Transition period is the period that bridges two different eras. For instance, we all have come across periodic table. There are few elements in the periodic table which are known to be “Transitional Elements”. The reason is that the position of the elements is somewhat in the middle of two different blocks (s block and p block). The block d is the transition between block s and p, thus the elements that fall in the block d are known as the “Transitional Elements”.

Main-group Elements		Transition Metals										Main-group Elements							
H																			
Li	Be																H	He	
Na	Mg											B	C	N	O	F	Ne		
K	Ca	Sc	Ti	V	Cr	Mn	Fe	Co	Ni	Cu	Zn	Al	Si	P	S	Cl	Ar		
Rb	Sr	Y	Zr	Nb	Mo	Tc	Ru	Rh	Pd	Ag	Cd	Ga	Ge	As	Se	Br	Kr		
Cs	Ba	La	Hf	Ta	W	Re	Os	Ir	Pt	Au	Hg	In	Sn	Sb	Te	I	Xe		
Fr	Ra	Ac	Rf	Ha	106	107	108	109				Tl	Pb	Bi	Po	At	Rn		

Lanthanides	Ce	Pr	Nd	Pm	Sm	Eu	Gd	Tb	Dy	Ho	Er	Tm	Yb	Lu
Actinides	Th	Pa	U	Np	Pu	Am	Cm	Bk	Cf	Es	Fm	Md	No	Lr

Similarly, the age that acts as the bridge between two eras is called transitional age. For instance, in the field of Western Classical Music, there are various eras such as Baroque, Romantic, Modern etc. In between two different ages, there were periods that amalgamated the previous with the next. In mathematical terms, there were overlapping domains between two different domains. The overlapping domain is known as the transitional period.

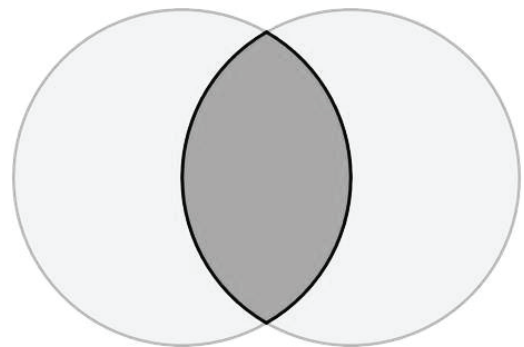

In terms of the context that we are discussing, the transitional period is the time frame when new inventions were setting in and bringing in revolution. There were two strictly separate eras. One was prior to the new inventions when everything used to be manual and the other one was the post invention era when machines and machine tools took over the industry.

The transition between these two periods has seen the incorporation of many new technologies. Post that period, researches have aggravated the scope and opportunity of growth in the industrial field. Now a days, we are witnessing typically computer based technologies where the productivity and accuracy have reached to the pinnacle. This has become possible by the introduction of CNC. In the next indent, we will discuss the basic concept of CNC.



### 1.3 What is CNC?

**CNC = COMPUTER NUMERICAL CONTROL**

CNC is the process of controlling various machines like lathe machine, drilling machine, electric saws and others automatically. This is performed rather executed by some pre-programmed sequences which control the entire process of manufacture or output system. Previously these were more or less manually controlled by the workers. The CNC system can be divided in two parts. Let's have a look at the very basic concept of programming.

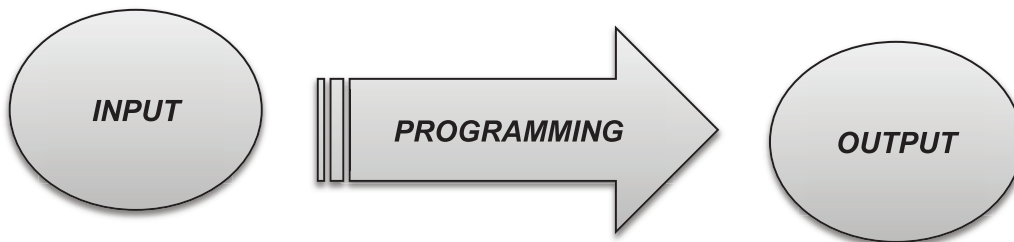

There is a similar flowchart followed in case of CNC as well. Whenever there is an expectation of output, we must have a valid input with strong programming system. CNC works in the same process. The flowchart of CNC is as follows:

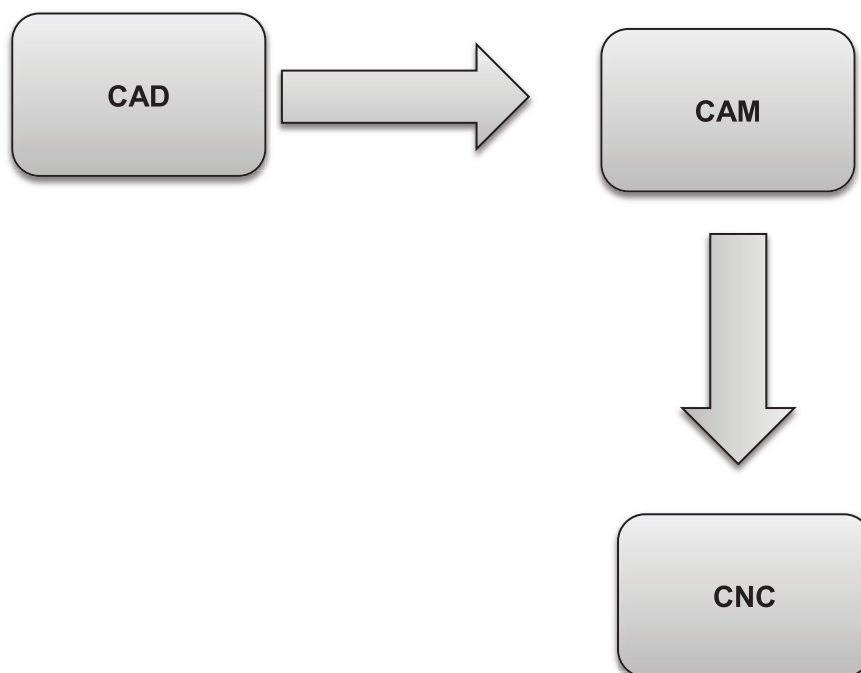

Now, let us know what are CAD and CAM.

### 1.3.1 CAD (Computer Aided Design)

□ **CAD:** Full form of CAD is Computer Aided Design. CAD controls the make of any mechanical parts of CNC machines. This is software that defines the mechanical dimensions of the mechanical parts. CAD can also be used enhance the productivity and accuracy of the machines. In very simple words the CAD helps to prepare the blueprint of any machine or mechanical tool/ part. The efficiency and working principle are considered along with the output of the machine at the time of preparing the blueprint. The CAD software aid to the entire delivery process of a machine.

In the early days of industrialisation, these blueprints were used to be drawn by the experts. For example, in case, any machine was supposed to be built, the experts would draw 2D diagrams of the machine from various angles to illustrate its view from different angles. However, there are examples where experts exploited 3D technique as well. One of the most notable instances of such case is the model of aeroplane drafted in 3D by the Renaissance virtuoso Leonardo de Vinci.

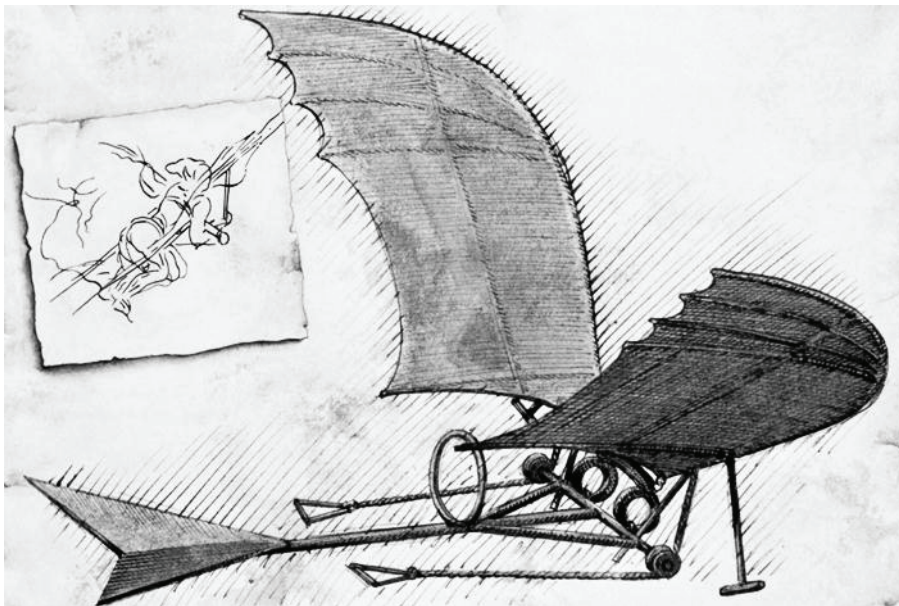

This can be taken as an example of early CAD where the experts used to draw the machines or a miniature of the machines manually. Afterwards, based on the diagram provided by the experts, mechanics would construct the tool. This system was of course quite lengthy and costly. Therefore, the introduction of computer drawn CAD software made the process easier and cost effective. It also allows one to be more accurate and error free.

The common practice in the mechanical engineering is to exploit the software available in the market to draft and design the machines. This allows the engineers to merge three different field and produce one and unique CAD system. These departments are Drafting, Designing and Engineering.

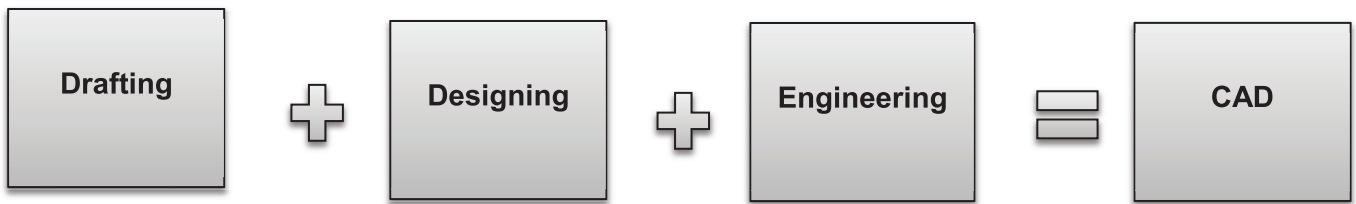

Design is a complex engineering activity, in which computers are more and more involved. The design task can often be seen as an optimization problem in which the parameters or the structure describing the best quality design are sought.

Genetic algorithms constitute a class of search algorithms especially suited to solving complex optimization problems. In addition to parameter optimization, genetic algorithms are also suggested for solving problems in creative design, such as combining components in a novel, creative way.

Genetic algorithms transpose the notions of evolution in Nature to computers and imitate natural evolution. Basically, they find solution(s) to a problem by maintaining a population of possible solutions according to the 'survival of the fittest' principle.

### 1.3.2 CAM (Computer Aided Manufacturing)

**CAM:** CAM is the subsequent programming that follows CAD. In CAD, the primary goal is to draw a valid design and draft it. However, CAM is the process of execution of the design perceived through CAD. In other words, whatever CAD drafts, CAM transcripts it in action. For instance, if a model is designed through CAD, CAM gives it a solidified form through proper manufacturing methods.

Again, if a simile has to be drawn to the traditional procedure of manufacturing something, the first thing that comes to our mind is the raw materials or ingredients. Nothing can be prepared without proper and adequate raw materials. In past, when things used to be built manually, raw materials were collected in adequate amount. However, as a precautionary measurement, the amount of raw material gathered used to be more than the required amount. Thus, once the product is manufactured, in most of the cases, a large amount of ingredients used to be thrown away as that was not used. This waste can be prevented by using CAM. An in built system allows CAM to evaluate the amount of raw materials required and it uses the exact amount of raw materials; which in turn saves the huge amount of waste associated to the manufacturing industry.

Few widely used CAD software:

- AutoCAD



- CATIA



- Free CAD



- Sketch Up



- Space Claim



Few widely used CAM software:

- Power Mill

The logo for Vericut, featuring the word "vericut" in a lowercase, sans-serif font.

- Siemens

The Siemens NX logo, consisting of the word "SIEMENS" in a bold, uppercase, sans-serif font above the word "NX" in a similar font, with a stylized graphic element to the left.

- Tebis

The Tebis logo, featuring the word "tebis" in a lowercase, bold, sans-serif font.

- Vericut

The Vericut logo, featuring the word "vericut" in a lowercase, bold, sans-serif font.

- Solid CAM

The Solid CAM logo, featuring the word "idC" in a large, bold, lowercase, sans-serif font, with the word "machining" in a smaller, lowercase, sans-serif font below it.

### 1.4 Job Responsibilities of CNC Operators

The basic job responsibilities of the CNC operators are –

- Planning machining by studying work orders, blueprints, engineering plans, materials, specifications, orthographic drawings, reference planes, locations of surfaces, and machining parameters; interpreting geometric dimensions and tolerances (GD&T).
- Preparing stock inventory by checking stock to determine amount available; anticipating needed stock; placing and expediting orders for stock; verifying receipt of stock.
- Programming mills and lathes by entering instructions, including zero and reference points; setting tool registers, offsets, compensation, and conditional switches; calculating requirements, including basic math, geometry, and trigonometry; proving part programs.
- Setting-up mills and lathes by installing and adjusting three- and four-jaw chucks, tools, attachments, collets, bushings, cams, gears, stops, and stock pushers; indicating vices; trimming heads.
- Loading feed mechanism by lifting stock into position.
- Verifying settings by measuring positions, first-run part, and sample work pieces; adhering to international standards.
- Maintaining specifications by observing drilling, grooving, and cutting, including turning, facing, knurling and thread chasing operations; taking measurements; detecting malfunctions; troubleshooting processes; adjusting and reprogramming controls; sharpening and replacing worn tools; adhering to quality assurance procedures and processes.
- Maintaining safe operations by adhering to safety procedures and regulations.
- Monitoring equipment by completing preventive maintenance requirements; following manufacturer's instructions; troubleshooting malfunctions; calling for repairs.
- Adhering to continuity among work shifts by documenting and communicating actions, irregularities, and continuing needs.
- Documenting actions by completing production and quality logs.
- Updating job knowledge by participating in educational opportunities; reading technical publications.
- Accomplishing organization goals by accepting ownership for accomplishing new and different requests; exploring opportunities to add value to job accomplishments.

[The source of the above mentioned responsibilities is <https://hiring.monster.com/hr/hr-best-practices/recruiting-hiring-advice/job-descriptions/cnc-operator-machinist-job-description-sample.aspx>.]



### 1.5 Advantages of CNC

❑ **Less Manpower:** Earlier when everything used to be controlled manually, the industry needed a lot of manpower to have the machines up and working. Not only it was costly, but also it involved various other perils like accidents causing loss of lives, wrong man management policy leading to frequent protests etc. However, with the introduction of CNC, machines can be controlled automatically by pre-set programming.

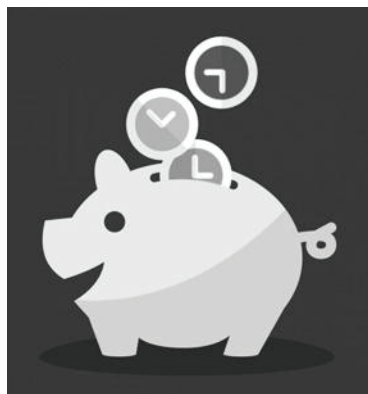

❑ **Time Saving:** Previously, the entire process associated to industry was quite lengthy and time consuming. Moreover, it used to take more time to transport the machines from the manufacturing hub to the factory. The machines built earlier used to be quite gigantic and the split parts of the machines used to be transported to the factory where the segregated parts used to be joined together.

❑ **Cost Effective:** Installing CNC machines is a onetime investment. It is indeed quite costly to install the CNC machines and of course the cost related to the proper maintenance of the machines is no small. However, in comparison to the manual procedure of building machines in manufacturing hubs, transporting it to the factory, wages of the workers, transportation cost etc. combined together is higher than the CNC installation and maintenance charges. Moreover, maintenance of the CNC machines is not too difficult, nor problematic.



## CNC Operator (Machining Technician)

---

- ❑ **Accurate:** There is a very old proverb widely used, “Too err is human” says it all. Whenever we tend to do something, even if take all the precautions to maintain perfection, there are possibilities of slight mistakes or drawbacks. However, CNC machines are run by the programs controlled and executed by the computers. Thus, the scopes of error are almost negligible. Therefore, for more accuracy and error-free, modern industrial technology uses CNC machines and CNC programs.



- ❑ **High GDP:** It is easy to understand that when something is controlled manually. It requires a lot of time. Therefore, the productivity is hampered badly. GDP means Gross Domestic Production which acts as a parameter of the productivity of a factory or any organization. Previously GDP used to be low as the whole system was controlled manually. However, implementation of CNC programming and CNC machines have enhanced the growth and the overall productivity of the organizations. This is leading to more profit and at the same time steady growth.



- ❑ **Easy Maintenance:** CNC machines are easy to maintain. As discussed earlier, CNC installation is a onetime investment that makes the half of the entire system ready to perform. However, whatever minimal requirements are there to maintain the machines are neither havoc nor too expensive.



**Debriefing**

1. Knowing brief history of machining industry
2. Learning the definition of CNC
3. Understanding the advantages of CNC
4. Knowing the cons of introduction of CNC
5. Understanding the job responsibilities of CNC operators

**Post Session Activity**

The trainer will divide the class in 3-4 groups. Each group should prepare chart paper demonstration to illustrate the flowchart of CAD, CAM and CNC. Trainees should draw flowcharts to represent their demonstration. The demonstration should take place in front of the entire classroom. Other than the participants, the trainees should be engaged with the activity by crosschecking the demonstrators. The best team will be recognized by the trainer.



**Test Yourself**

1. Full form of CAD is \_\_\_\_\_.
2. Write three advantages of CNC?

---

---

---

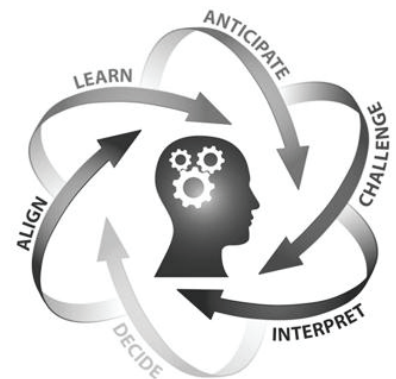

3. What are the major changes that took place during industrial revolution? (write any two)

---

---

4. What is the CAD-CAM-CNC flowchart?

---

---

5. What are the job responsibilities of a CNC operator? (write any three)

---

---

---

## CHAPTER - 2

# DIFFERENT TYPES OF MACHINING PROCESSES

### LEARNING OUTCOMES:



- Learning the processes used in the machining industry
- Knowing the tools exploited to carry out various processes
- Impact of various machining processes on the outcome
- Getting acquainted with the fundamental theory of machines and mechanic
- Understanding the safety guidelines in the machining industry
- Vitalizing the application of lubricant and coolant

---

### PRE-SESSION ACTIVITY:

The trainer will take the trainees to the lab for hands on. For example, the trainer will make the trainees to various processes exploited in the industrial sector and the respective tools used. The trainer will explain the usages of the tools that are used for processes like facing, turning, grinding etc.

### 2.1 Machining Processes: Various Types

The things which use in our daily life are actually outcomes of manufacturing industry. Anything from safety pin, screw to machines like refrigerator and washing machine – all are manufactured in certain industries. Machining is the manufacturing process. In other words, machining is exploited in various manufacturing industries to manufacture different items. This needs not only manpower and capital, but also subtle mathematical calculations to figure out the exact method that is to be exploited in the machining process.

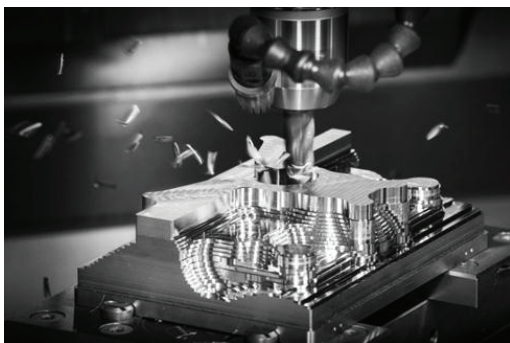

## CNC Operator (Machining Technician)

---

Machining is mainly required to remove the unwanted material from the work piece. The work piece material might be a hollow tube or a huge sheet or simply a bar. It is the machining process that ensures perfect shaping and thus in turn, the final outcome. Mainly large stocks are used to cut and give proper shapes to the work pieces.

Machining process can be divided in three major components –

1. Turning
2. Drilling
3. Milling

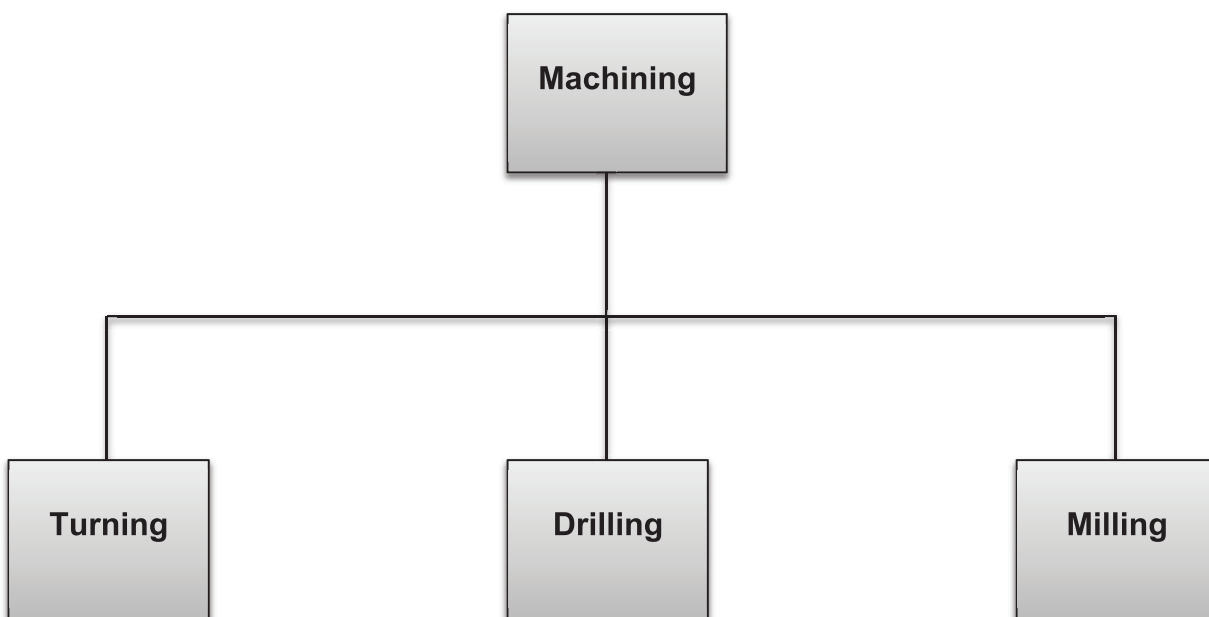



### 2.1.1 Turning Process

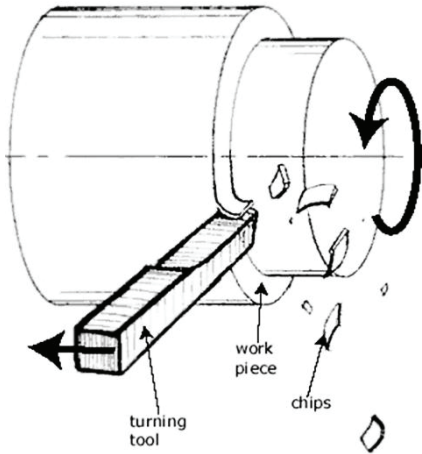

Turning is basically a lathe operation by which the metal is removed from the work piece outside its diameter using a cutting tool. This operation is performed on a lathe which is a machine where the work piece is adjusted and the tool is kept stationary whereas the work piece is rotated. Lathes are specially designed for the turning operation and they help in cutting the metal in the most precise way. The work piece is placed on the chuck and the machine rotates the stationary tool to cut the unwanted parts from the piece.

### 2.1.2 Drilling Process

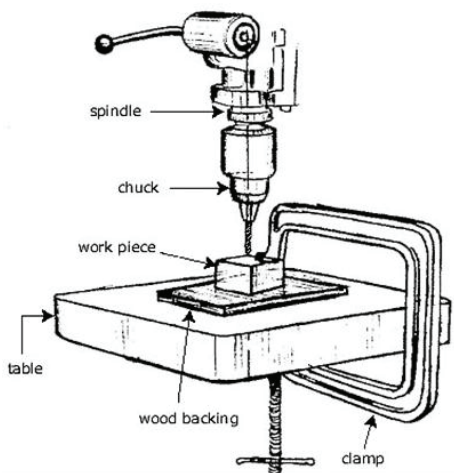

In drilling process holes are created in the metal through circular cylinders. A twist drill is used for accomplishing this task. 75% of the metal cutting material is removed through the drilling operation. The drill enters the work piece and cuts a hole which is equal to the diameter of the tool that was used for cutting the whole. A drill has a pointed end which can easily cut a hole in the work piece.

### 2.1.3 Milling Processes

Milling is one of the fundamental operations in machining. This manufacturing process is less accurate than the turning processes because the degree of freedom is high. Milling fabricates the object which is not axially symmetric. A milling machine is required for this purpose along with a fixture, cutter and of course the work piece. The work piece here is the material that is already shaped and it needs milling. It is secured to the fixture, ready for being milled. The cutter is also secured to the machine. It has sharp teeth and it rotates at a high speed. The work piece is fed to the cutter and it removes the unwanted metal from the piece.

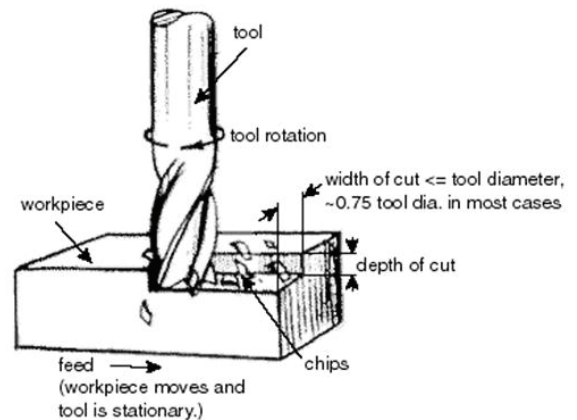

### 2.1.4 Other Processes

Apart from the processes mentioned above, there are few other processes that are exploited generally in the manufacturing industry. These processes are exploited mainly to get the desired effect or result. These are almost like the final touch to the product. Some of these processes are –

- Facing
  - Threading
  - Boring
  - Shaping
  - Grinding
- **Facing:** Facing is the machining process that is chiefly used to get the desired face or the end face of the final product. For instance, if the product is a simple screw, assume the two ends of it. One end is the flat hexagonal shaped figure whereas the other end is the sharp and coiled portion which gets into the object. Facing is used to create these two ends. Same is applicable for any product.
- **Threading:** The other name for the term threading is coiling. Threading refers to the coiling of the product. Illustrating an example will be helpful to make the topic easy to understand. Take the example of screw again. Look at the picture of the screw. There is a prominent coiling on the body of the screw. The coiling is necessary to make the screws more efficient and fitting. This will be discussed in details in the next chapter under the topic tolerance limit.
- **Shaping:** Shaping is the process that is mainly exploited to create the rough cut of the final product. We all watch movies. There is a term used widely in movies – “rough cut”. Rough cut refers to the first cut of the final product. Whenever something is to be manufactured, it needs to go through various processes like turning, drilling, facing and etc. post these steps, shaping is used to create a rough version of the final product. Shaping is performed mainly before milling. In milling, the objects are smoothed and given the final shape. Shaping prepares an object for milling.

